

# Design specifications Volocopter 2X

Preliminary development status (April 2017)



## 1 General

Classification	VTOL (vertical take-off and landing); rotary wing aircraft
Certification	Light sport multicopter; German ultralight (UL)
Power type	Electric/batteries
Passenger capacity	2 pax

## 2 Performance

Max. take off mass (MTOM)	450 kg
Max. payload	160 kg
Operating weight empty (OWE)	290 kg
Max. range (@ MTOM) <sup>1</sup>	27 km (17 mi) at an optimal 'range' cruise speed of 70 km/h (43 mph)
Max. flight time (@ MTOM) <sup>1</sup>	27 min at an optimal 'flight time' cruise speed of 50 km/h (31 mph)
Max. airspeed (limited time)	100 km/h
Rate of climb (@ MTOM)	3 m/s
Rate of descent	2,5 m/s
Altitude (service ceiling)	≥ 2.000 m AMSL
Altitude (hovering)	≥ 1.650 m AMSL
Noise level	~ 65 dB(A) at 75 m
Safety & redundancy concept	<ul style="list-style-type: none"><li>- Full aircraft emergency parachute</li><li>- Multiple redundancy in all critical components such as propellers, motors, power source, electronics, flight control, displays</li><li>- Highly reliable communication network between devices through meshed polymer optic fiber network ('fly-by-light')</li></ul>

## 3 Structures

Composition/structure	Fibre composites; lightweight construction
Overall height	2,15 m
Rotor plane	6 hub-arms; 1 holm and 3 engine heads per hub-arm
Diameter of the rotor rim incl. propellers	9,15 m
Diameter of the rotor rim excl. propellers	7,35 m
Diameter of a single propeller	1,80 m
Cockpit	3,20 m length / 1,25 m width / 1,21 m height
Skids	3,02 m length / 2,06 m width

## 4 Powertrain

### a) Power supply & battery

Number of battery packs	9 independent battery systems with quick release
Battery type	Lithium-ion battery
Power supply	9 batteries supply 2 motors each
Max. charging time	< 120 min
Fast charging time	< 40 min
Battery changing system	Quick-change system; plug-in system
Battery cooling	Active air cooling

### b) Motors & rotors

Number of motors & rotors	18 each
Engine type	3-phase PM synchronous motor, brushless DC electric motor (BLDC)

<sup>1</sup> Additional battery capacity to extend range and flight time - *integration possible*

# Design specifications Volocopter 2X

Preliminary development status (April 2017)



## 5 Flight control system

Elements	1 triple redundant primary flight control unit 1 dissimilar backup flight control unit 1 joystick (includes friction clutch to set cruise speed)
Sensors	Gyroscopes, acceleration sensors, magnetic field measurement sensors, manometers
Data network	Optical data transmission via polymer optical fibers
Options to control	Piloted, interactive one-hand control via joystick
Features	Continuous data recording, hundreds of times per second

Automatic Attitude Control

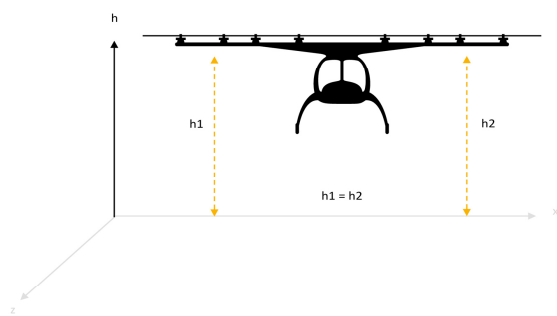

Automatic Altitude Control

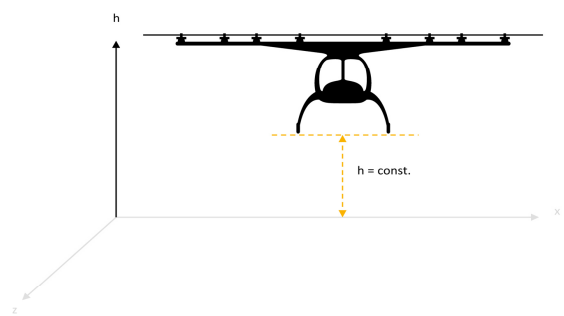

Assisted Landing

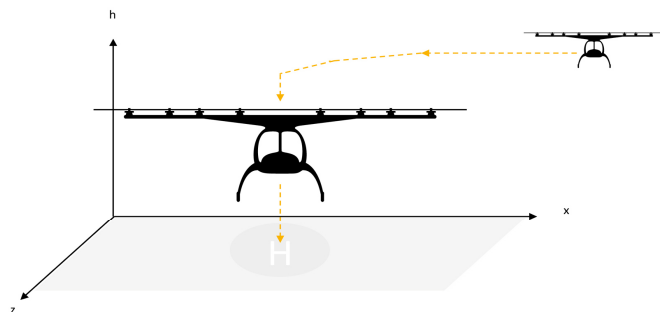

Automatic Position Hold<sup>2</sup>

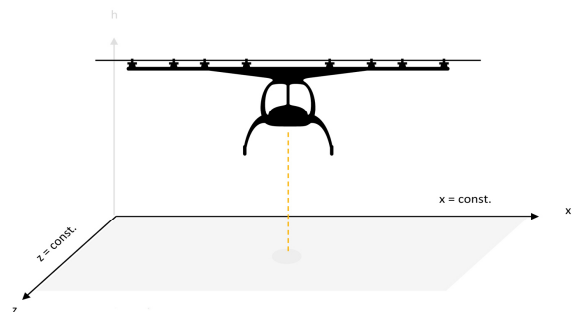

## 6 Price (certified as ultralight aircraft)

Estimated selling price	Available upon request
-------------------------	------------------------

## 7 Extra features for specific applications<sup>2</sup>

- Remote control (RC) - *already assimilable*
- GPS point tracking - *already assimilable*
- Sense & avoid - *integration possible*
- Autonomous subfeatures - *integration possible*
- Additional battery capacity to extend range and flight time - *integration possible*
- Air traffic management (including UTM) to coordinate autonomous Volocopter fleets - *integration possible*
- In general, available UAV technology can be integrated into the Volocopter

<sup>2</sup> Unavailable for certified UL aircraft. Available in the framework of pilot projects approved by relevant authorities, e.g. Volocopter air shuttle service.